

# Power Supply Control System for Lamp-Pumped Lasers



The power supply control system for lamp-pumped lasers mainly consists of a master control unit, a 1000-2000W pulsed xenon lamp power supply, an industrial touchscreen, and a water-cooling system. It is designed to drive RealLight's HQF series lamp-pumped high-energy solid-state lasers with different wavelengths. This system can be adapted to different types of lamp-pumped lasers, including Q-switched and MOPA picosecond lasers, and is compatible with various accessories such as articulated arms and optical fibers. It is widely used in multiple fields including spectral analysis, radar sensing and biomedicine.

## Applications

- Radar ranging
- Biomedical applications
- Laser-induced breakdown spectroscopy (LIBS)
- Laser ultrasonic measurement
- Laser-induced fluorescence (LIF)
- Particle image velocimetry (PIV)

## Key Features

- ◆ User-friendly touch screen display and control
- ◆ Includes emergency stop switch, enable switch and switch protection function
- ◆ Includes water flow monitoring and temperature monitoring functions
- ◆ Internal trigger and external trigger modes
- ◆ Optional optical shutter and energy monitoring function
- ◆ Highly integrated, easy to transport and maintain

## Technical Specifications

Part Number	SCR-1kW-220V	SCR-2kW-220V
Power (W)	1000	2000
Power Supply Type	Silicon Controlled Rectifier	
Program Functions	Touchscreen control, RS232 remote communication control, internal and external	
Display Language	Default English, multi-language framework reserved	
Cooling Method	Air cooling	
Power Supply Requirements	220V±10%AC, 50/60Hz, 10A	220V±10%AC, 50/60Hz, 16A
Operating Environment	Temperature: 15~30°C, Relative Humidity: <60%	
Storage Temperature (°C)	-20~60	

Notes:

1. The system must be drained and stored when the temperature falls below 0°C.
2. The operating environment should be free from dust and smoke.
3. A 110V power input can be customized.
4. All the data in the above table are the typical values obtained from the tests at room temperature of 25°C, and the final data is subject to the final test report.

## Part Numbering Schema

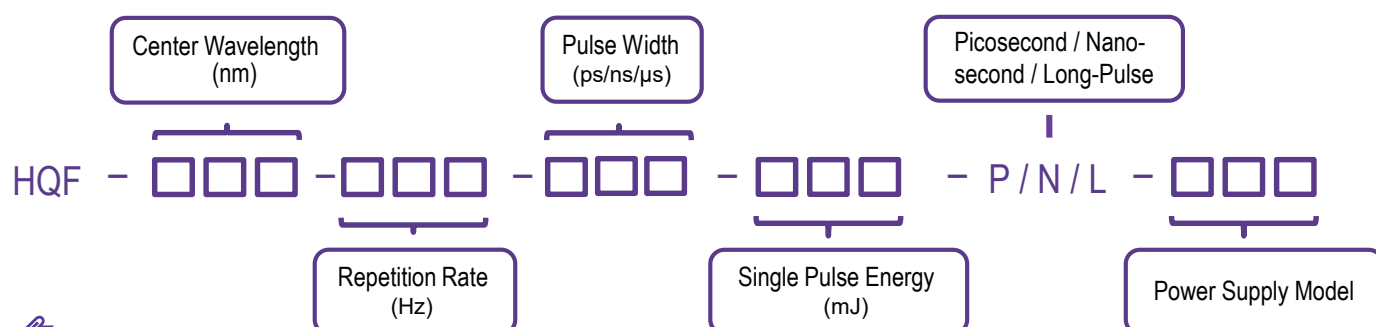

## Functional Diagram

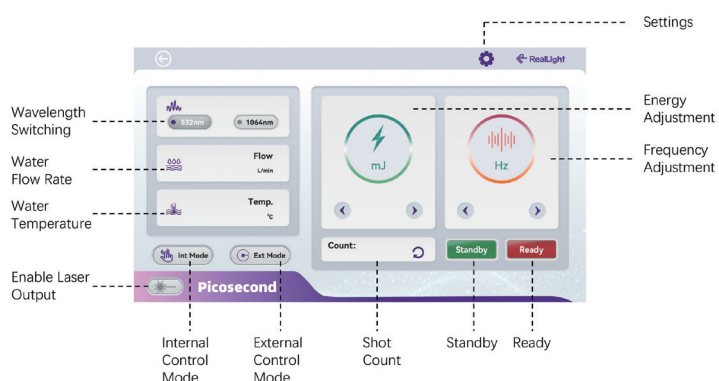
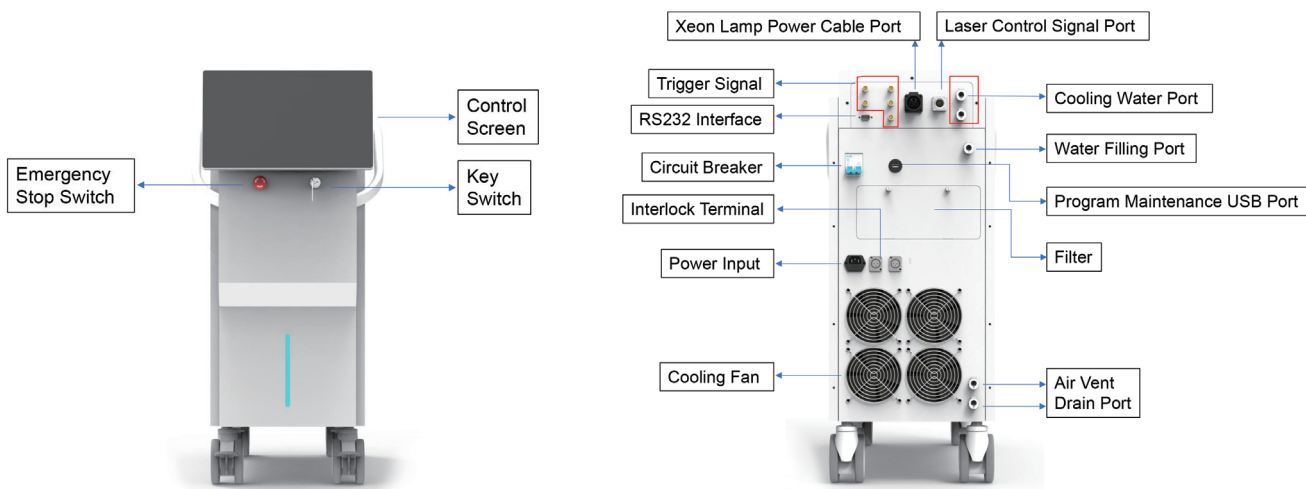

Control Screen

## Mechanical Drawings (in mm)

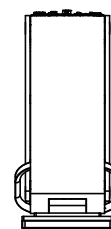
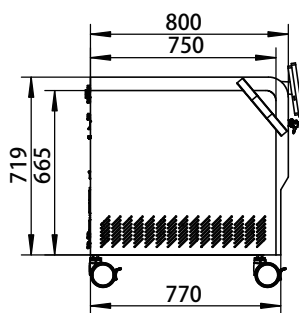
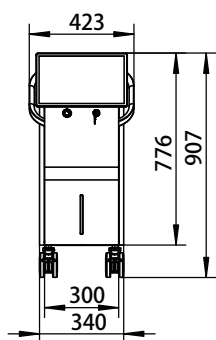

SCR-1kW-220V

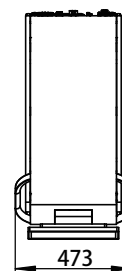
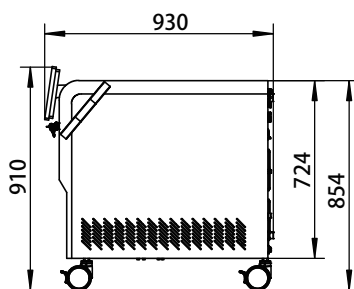
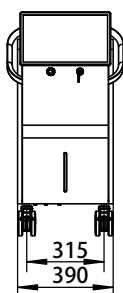

SCR-2kW-220V